

Fuel Pump FP 200

www.bosch-motorsport.com

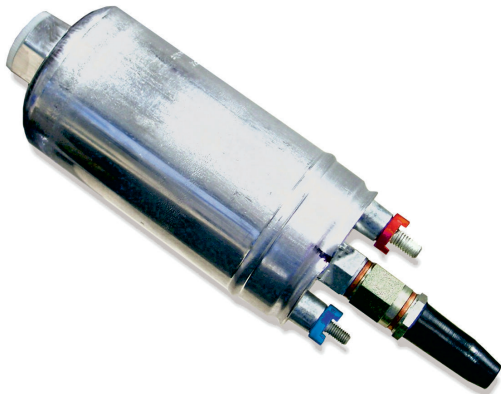

BOSCH
Invented for life



- ▶ >200 l/h
- ▶ 1,030 g
- ▶ Max. 5 bar/8 bar
- ▶ Fuel lines screwed

The FP 200 is an inline roller cell pump for the installation outside or inside the fuel tank. It is capable of providing 200 l/h at 5 bar (8 bar). Bio-fuel can be delivered up to E85. The FP 200 is one of the most popular aftermarket fuel pumps and has an excellent price.

Application

Fuel pressure	5 bar or 8 bar
Delivery rate at 5 bar and 22°C	260 ± 5 l/h at 14 V
Delivery rate at 8 bar and 22°C	220 ± 5 l/h at 14 V
Pressure limiting valve	10 to 12.5 bar rel.
Fuel compatibility	E85
Operating temperature range	-20 to 90°C
Storage temperature range	-40 to 70°C
Max. vibration	3 mm at 10 to 18 Hz ≤40 m/s ² at 18 to 60 Hz

Technical Specifications

Mechanical Data

Diameter	60 mm
Length	196 mm
Weight	1,030 g
Mounting	Clamping

Electrical Data

Supply voltage	6 to 16.5 V
Operating voltage	13.8 V
Load current at 5 bar and 22°C	14 ± 1 A
Load current at 8 bar and 22°C	15 ± 1 A

Characteristic

Surface coating	None
Color	Silver
Non-return valve	External
Fuel filtering	External, on pressure side

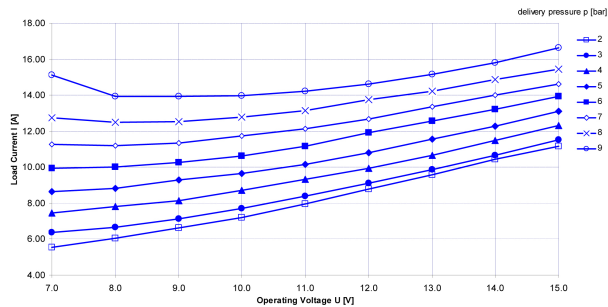
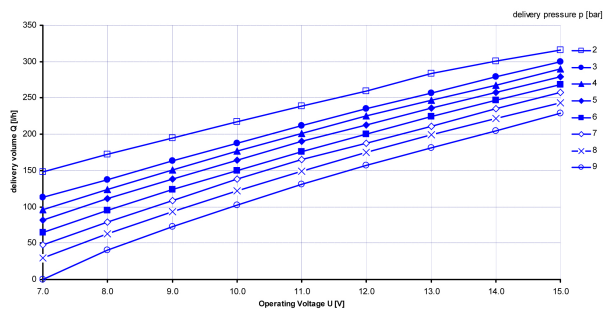
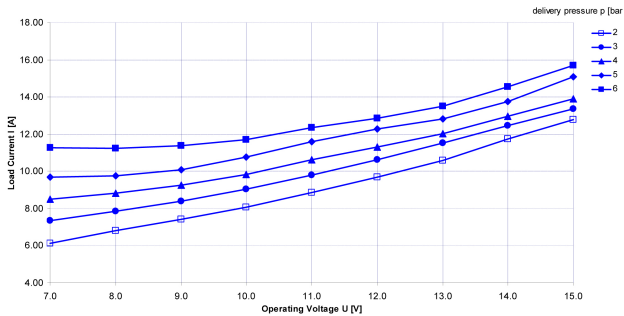
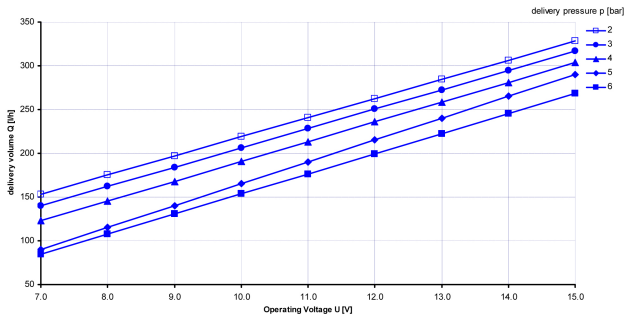

Installation Notes

With E26/E85 or Diesel fuel run-time max. 500 h.

For technical reasons the values may vary.

Please use within the specified limit values only.

Please find further application hints in the offer drawing at our home-page.

Ordering Information

Fuel Pump FP 200, 5 bar

Order number 0 580 254 044

Fuel Pump FP 200, 8 bar

Order number B 261 205 413-01

Connectors and Wires

Electrical connector	+M6/-M5
Electrical matting connector	With ring wire M6 and M5
Mechanical connector intake side	M18x1.5
Mechanical connector pressure side	M12x1.5

Dimensions

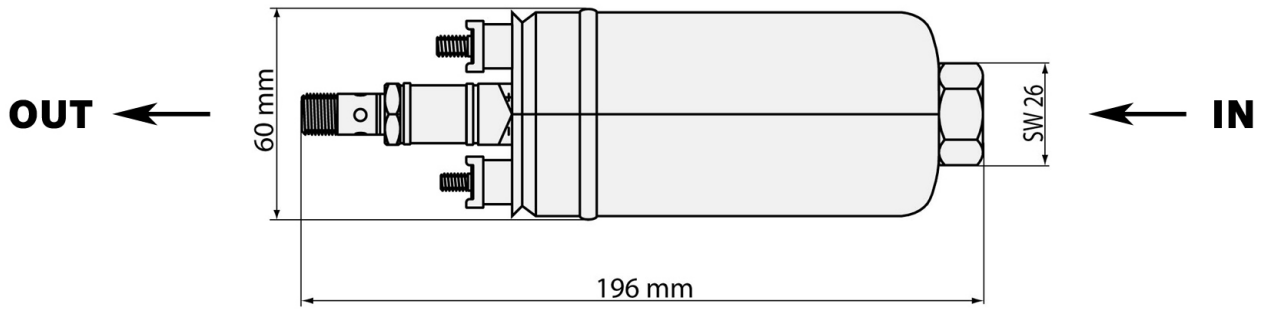

Represented by:

Europe:
Bosch Engineering GmbH
Motorsport
Robert-Bosch-Allee 1
74232 Abstatt
Germany
Tel.: +49 7062 911 79101
Fax: +49 7062 911 79104
motorsport@bosch.com
www.bosch-motorsport.de

North and South America:
Bosch Engineering North America
Motorsports
38000 Hills Tech Drive
Farmington Hills, MI 48331-3417
United States of America
Tel.: +1 248 876 2977
Fax: +1 248 876 7373
motorsport@bosch.com
www.bosch-motorsport.com

Asia-Pacific:
Bosch Engineering Japan K.K.
Motorsport Department
18F Queen's Tower C, 2-3-5 Minato Mirai
Nishi-ku, Yokohama-shi
Kanagawa 220-6218
Japan
Tel.: +81 45 650 5610
Fax: +81 45 650 5611
motorsport@bosch.com

Australia and New Zealand:
Robert Bosch Pty. Ltd
1555 Centre Road
Clayton, Victoria, 3168
Australia
Tel.: +61 (3) 9541 3901
Fax: +61 (3) 9541 7225
motor.sport@au.bosch.com